

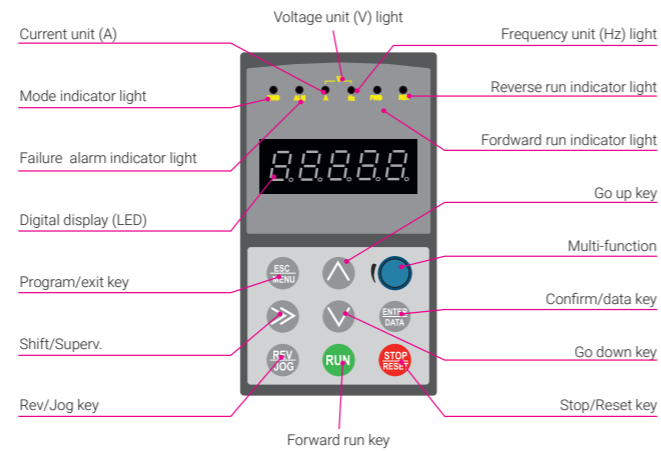

Variable Frequency Drives

Keypad layout sketch



Key	Name	Function description
	Program/Exit key	Enter into or exit programming state
	Shift/Supervision key	Can choose modification digit of set data under editor state; can switch display status supervision parameter under other state
	Function/Data key	Enter into or exit programming state
	Rev/Jog key	Under keypad mode: to press this key can set reverse run or Jog run according to the 1st bit of parameter F00.15
	Run key	Enter into forward run under keypad mode
	Stop/reset key	In common run status the inverter will be stopped according to set mode after pressing this key if run command channel is set as keypad stop effective mode. The inverter will be reset and resume normal stop status after pressing this key when the inverter is in malfunction status
	Multi-function key	The specific function keys decided by tens digit of F00.15 see F00.15 parameter descriptions
	Increasing button	To increase data or function code (press and hold this key to improve increasing speed)
	Decreasing button	To decrease data or function code (press and hold this key to improve decreasing speed)

General drive control system

Function	Set range	Code	Remarks
F00.23	G/P type setup	1	V/F control
F01.04	Auxiliary frequency digital panel setup	50.00	Hz
F01.11	Upper limit frequency	50.00	Hz
F01.12	Low limit frequency	30.00	Hz
F01.15	Run command channel selection	1	Run command control (Basic running wiring diagram)
F08.18	Input terminal X1 function selection	1	Forward running FWD (Basic running wiring diagram)
F01.17	Acceleration time 1	50	Base on motor type (=5s)
F01.18	Deceleration time 1	50	Base on motor type (=5s)

Asynchronous Motor Parameter Group

Function	Set range	Unit	Remarks
F15.01	Asynchronous motor rated power	KW	Base on motor type
F15.02	Asynchronous motor rated voltage	V	Base on motor type
F15.03	Asynchronous motor rated current	A	Base on motor type
F15.04	Asynchronous motor rated frequency	Hz	Base on motor type
F15.05	Asynchronous motor rated speed	r/min	Base on motor type
F15.06	Asynchronous motor poles No.	1...7	Base on motor type

Monitor function parameter group

Code	Set range	Function	Factory default
0	Main setup frequency (0.01Hz)	F00.01 / C-00 / RUN	51
1	Auxiliary setup frequency (0.01Hz)	F00.02 / C-01 / RUN	2
2	Setup frequency (0.01Hz)	F00.03 / C-02 / RUN	4
3	Output frequency (0.01Hz)	F00.04 / C-03 / RUN	5
4	Output current (0.1A)	F00.05 / C-04 / RUN	6
5	Output voltage (1v)	F00.06 / C-05 / RUN	9
6	Dc busbar voltage (0.1V)	F00.07 / C-00 / STOP	2
7	Motor speed (1 circle/min)	F00.08 / C-01 / STOP	6
8	Motor line velocity (1 circle/min)	F00.09 / C-02 / STOP	48
9	Inverter temperature (1°C)	F00.10 / C-03 / STOP	14
10	Run time (0.1Min)	F00.11 / C-04 / STOP	20
11	Current accumulate run time (1h)	F00.12 / C-05 / STOP	9
12	Current accumulate power-on time (1h)		
13	Inverter status		
14	Input terminal status		
15	Output terminal status		
20	Analog input ai1 (after checkout) (0.01V / 0.01mA)		
21	Analog input ai2 (after checkout) (0.01V / 0.01mA)		
22	Extension analog input eai1 (after checkout) (0.01V / 0.01mA)		
23	Extension analog input eai2 (after checkout) (0.01V / 0.01mA)		
24	Analog ao1 output (after checkout) (0.01V / 0.01mA)		
25	Analog ao2 output (after checkout) (0.01V / 0.01mA)		
28	External pulse input frequency (before checkout)(1Hz)		
30	Process pid provide (0.01V)		
31	Process pid feedback (0.01V)		
32	Process pid deviation (0.01V)		
33	Process pid output (0.01Hz)		
35	External multi-speed current segment no.		
36	Constant pressure water supply provide pressure (0.001Mpa)		
37	Constant pressure water supply feedback pressure (0.001Mpa)		
38	Constant pressure water supply relay status		
41	Current internal count value		
42	Current internal time value		
43	Run command setup channel (0:keyboard 1:terminal 2:communication)		
44	Main frequency provide channel		
45	Auxiliary frequency provide channel		
46	Rated current (0.1A)		
47	Rated voltage (1v)		
48	Rated power (0.1Kw)		
51	Frequency after acce/dece (0.01Hz)		
52	Motor rotor frequency (0.01Hz)		
53	Current given torque (percentage relative to rated torque, with direction)		
54	Current output torque (percentage relative to rated torque, with direction)		
55	Present torque current (0.1A)		
56	Present flux current (0.1A)		

Factory monitoring varies with the programmed applications. The one indicated in this guide is the most used for this applications.

Item	Function description
Digital display	Indication of the current status of the operation and adjustment of the parameter
Status indicator light	A, Hz, V Unit for relevant current digital displayed physical parameter (for current is A; for voltage is V; for frequency is Hz)
	MOD This indicator light is lit in non-supervision status; if no key pressed for a minute: then come back to supervision status
	ALM Alarm indicator light: indicates that the inverter is currently in overcurrent or overvoltage state or in fault alarm state
	FWD Forward run indicator light indicate that the inverter output forward phase order and the connected motor rotate in forward direction
REV Reverse run indicator light: indicate that the inverse phase order of the inverter output and the connected motor are rotating in reverse	The inverter work in DC brake status if FWD, REV indicator lights are lit at the same time

Status parameter display switching

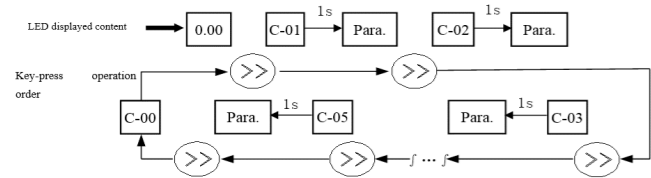

Function code parameter setting

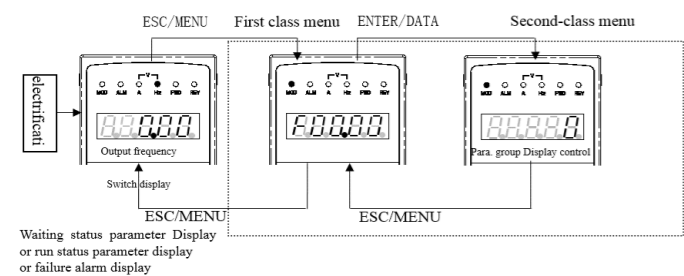
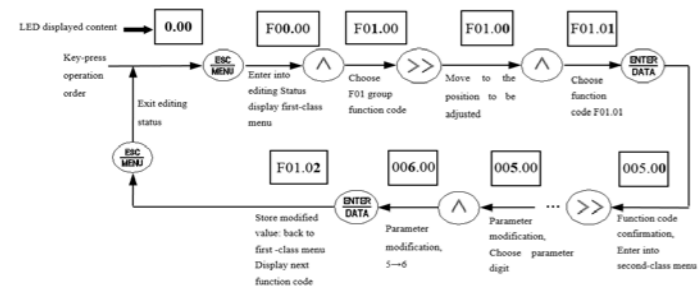

Waiting status parameter Display or run status parameter display or failure alarm display

Service  
Phone (+34) 954 999 900

Toscano Línea Electrónica, S.L.  
Autovía A-92, Km. 6,5 - 41500 - Alcalá de Guadaíra - SEVILLA -  
SPAIN - (+34) 954 999 900  
www.toscano.es - info@toscano.es



### Special applications: solar pump inverter

Function	Set range	Code	Remarks
Variation of the motor speed through the voltage in solar panels. MPPT mode (recommended)			
F01.03	Auxiliary frequency input channel select	20	
F11.01	Provide channel selection	9	Setup by F12.14 (CVT target voltage)
F11.02	Feedback channel selection	9	DC BUS voltage
F12.14	CVT target voltage	V	Depending on model(**)
F17.09	MPPT Mode Function	1	MPPT
F01.00	Main frequency input channel selection	11	MPPT provision frequency
F17.06	Wakeup DC Voltage	V	example: TDS600-2S=290Vcc TDS600-4T=500Vcc
F17.07	Sleep DC Voltage	V	example: TDS600-2S=200Vcc TDS600-4T=400Vcc
F17.08	MPPT Low limit Frequency	37.00	Hz
F17.10	Wakeup delay time	seconds	example 30s
F17.11	Nominal input voltage	Vn	example: TDS600-2S=310Vcc TDS600-4T=540Vcc

Maintain the speed of the motor according to the voltage of the solar panels. CVT mode. See user manual developed.

\*CVT and MPPT: Water upper limit level and Water low limit level functions available, please refer to #72 and #73 functions for multi-input function terminal at F08.

### TDS600 solar pump inverter Specifications

Type	4T series	2S series
Max input DC voltage (**)	800V DC	400V DC
Admissible MPPT&CVT voltage range	350V~750V DC	160V~380VDC
Nominal input voltage	530VDC/380VAC	310VDC/220VAC
Rated output voltage	3PH 380V AC	3PH 220V AC
MPPT efficiency	>97%	
Output frequency range	0~600Hz	
Max efficiency	>97%	
Protection level	IP20 Forced Air cooling	

#### Recommended solar array configurations.

The power range of solar array should be 1.2 to 1.3 times of the rated power of inverter. The open-circuit voltage of solar array should be 1.1 times to 1.2 times of rated DC bus voltage.

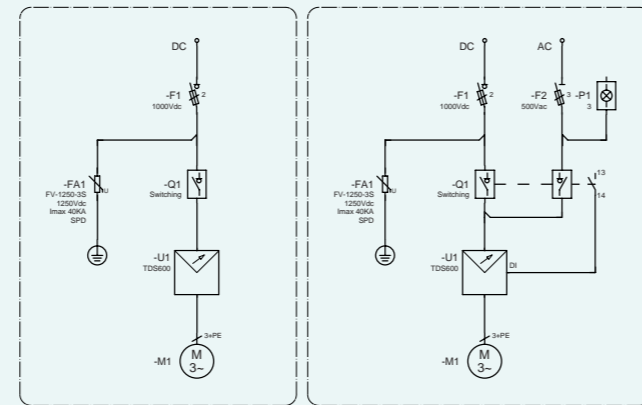

### Application to maintain water pressure by PID setpoint.

Pressure transducer MBS1900 required

Function	Set range	Code	Remarks
AC Power Supply			
F00.20	Analog input terminal configuration	0010	AI2 Analog 4-20mA
F01.00	Main frequency input channel selection	00	
F01.03	Auxiliary frequency input channel select	20	
F11.00	Close loop run control selection	1	PID close loop run control valid
F11.01	Provide channel selection	0	
F11.02	Feedback channel selection	1	AI2 analog input
F11.13	Close-loop adjust characteristic	0	action
F11.16	PID adjusting low limit frequency	30.00	Hz
F12.00	Constant pressure water supply mode selection	1	
F12.06	Long-distance pressure gage range	Base on motor type	(example 10 bar) (9.999 for 0-10 bar)
F12.01	Target pressure setup	Base on motor type	(example 4 bar, 4.000) (>F12.03)
F12.02	Sleep frequency minimum value	Base on motor type	(commended 37Hz)
F12.03	Wakeup pressure minimum value	Base on motor type	(example 3 bar, 3.000) (<F12.01)
F12.04	Sleep delay time	10.0	seconds
DC Power Supply			
F19.00	Power off restart waiting time	20.00	0 means no start function
F19.01	Fault self-recovery times	60000	0 means no automatic reset function
F19.02	Fault self-recovery interval time	reset time	seconds
F19.32	Undervoltage fault indication action selection	1200	

### Application for water extraction from wells or reservoirs by PID setpoint.

Submersible level Transmitter SN420 required

Function	Set range	Code	Remarks
*Same configuration as application with PID pressure transducer (AC or "DC Solar Energy")			
F11.14	Feedback channel plus-minus characteristic	1	negative characteristic
*Target pressure and awake pressure minimum value, To consider the vacuum level of the water column			
F12.01	Target pressure setup	Base on motor type	(example 8 m.)
F12.03	Wakeup pressure minimum value	Base on motor type	(example 2 m.)

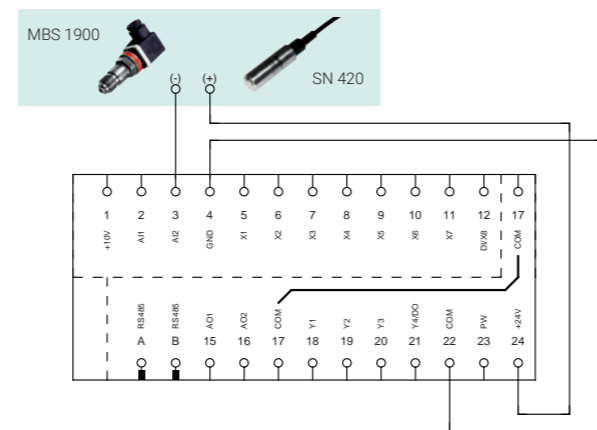

### Basic running wiring diagram

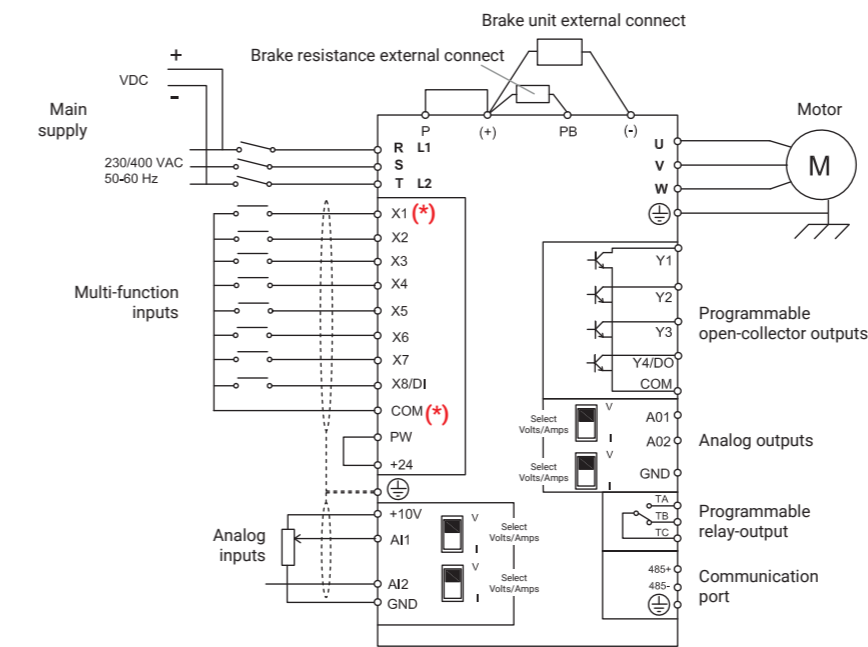

(\*) F01.15 and F08.18 functions (see "General drive control system")

### Motor underload alarm (PID not supported)

Function	Set range	Code	Remarks
*Adjustment of installation according to motor			
F19.00	Power off restart waiting time	>0	0: no start function
F19.01	Fault self-recovery times	>1	0: no automatic reset function
F19.02	Fault self-recovery interval time	s Base on motor type	seconds
F19.08	Motor underload alarm detection level	% Base on motor type	motor rated current
F19.09	Motor underload alarm detection time	s Base on motor type	seconds
F19.10	Motor underload alarm detection action	22	

### Analog input disconnection protection

Function	Set range	Code	Remarks
F07.15	Analog input disconnection protection option	10.0	seconds (>F01.17 & F01.18)
F07.16	Analog disconnection protection option	12	Fault, free stop / AI1

### Return to default

Function	Set range	Code	Remarks
F00.14	Parameter operation control	010	All parameters return to default. (not include fault record parameter group (F26 group) parameter)

### Multipumps

Function	Set range (output setup)	Code	Remarks
F09.00	Open collector terminal Y1	37	1° Drive
F09.01	Open collector terminal Y2	38	1° DOL
F09.02	Open collector terminal Y3	39	2° Drive
F09.03	Open collector terminal Y4	40	2° DOL

